

7/3/2018

SEBA FCAPS User Stories

Michael Gasser

AT&T Access Architecture



SEBA FCAPS – User Stories

SEBA POD deployment is a key VOLTHA scenario

- This is accomplished by locating the computing resources running the VOLTHA hardware abstraction and management applications with the VOLTHA hardware components in the CO edge
- Moving forward quickly with a MVP VOLTHA solution leads AT&T to believe the fastest path is to deploy a small peripheral POD in the CO
- This POD will contain:
 - Compute, fabric (agg), and VOLTHA as hardware resource
 - SEBA, NEM, ONOS, ONOS Apps, and VOLTHA for software resources
- SEBA/NEM will provide an access abstraction layer to the VOLTHA specific implementation



SEBA Reference Architecture Diagram

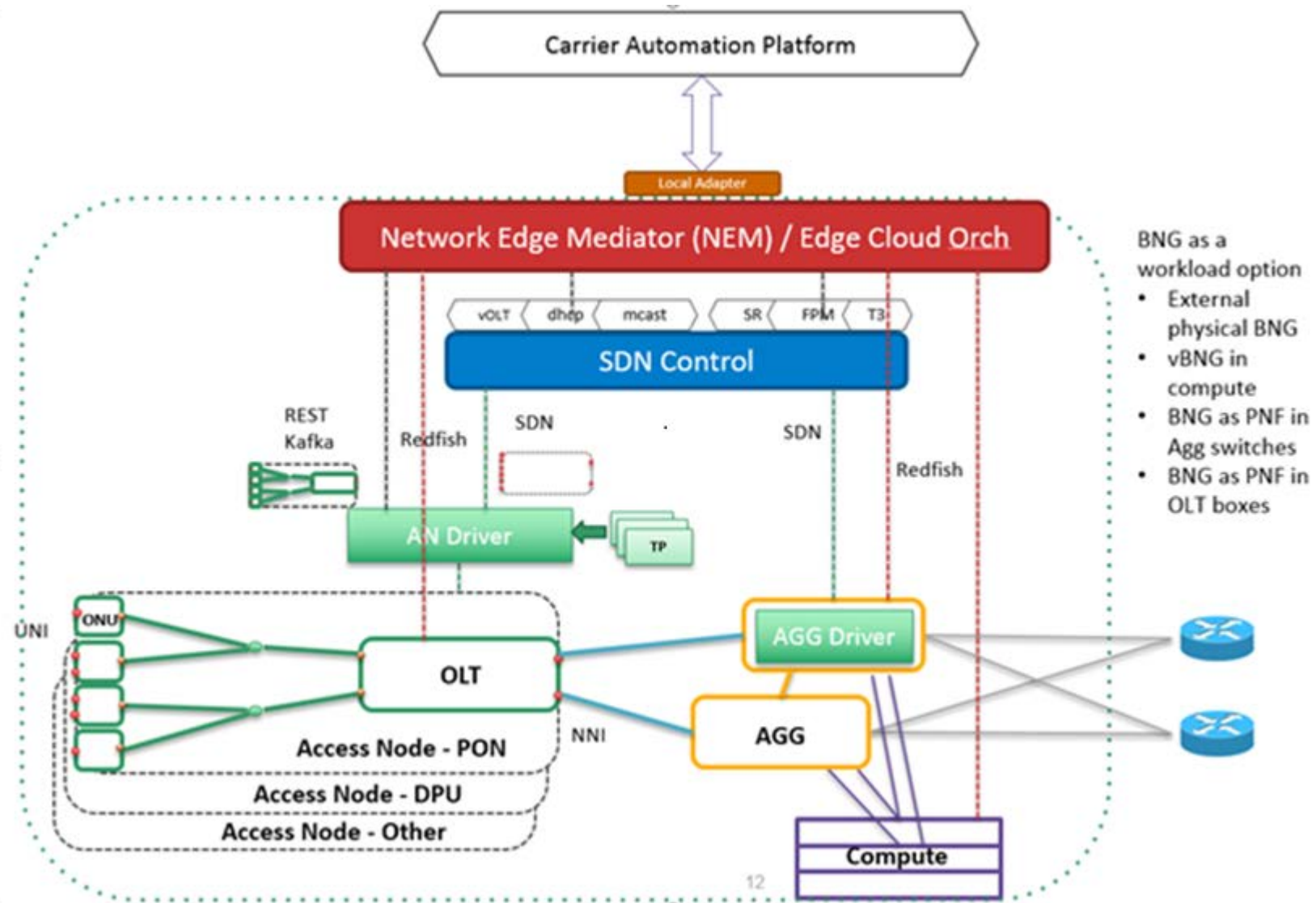

SEBA FCAPS - Management

SEBA POD Management

- A yang model interface can provide a flexible and easy to manage interface
- The BBF WT-383 models provided in the BBF provided many of the required interface definitions
- These models can be applied to a possible top down provisioning model as well as provide the various FCAPS interfaces required to operate the POD
 - Providing a top down management model is not intended to impede the implementation of a bottom up model being implemented in VOLTHA 2.0
 - An abstract access model is envisioned to be the glue that can merge the two model
- Areas of management
 - POD Management
 - OLT Management
 - ONT Management
 - Profile Management
 - Service Provisioning
 - Status Reporting
 - Alarm Management (to be discussed)
 - Performance Monitoring (to be discussed)



SEBA FCAPS – POD

POD Management

- Manage hardware life cycle for common hardware components, fabric, compute
 - Provide inventory information for common hardware component
- Life cycle manage software components
 - Download and manage software upgrades for SEBA, NEM, ONOS, ONOS Apps, and VOLTHA components
 - Provide support for add-on components to be managed (Local OSAM, Legacy Management Driver, Local Adapter e.g.)
- Monitor common hardware resources
 - Provide detail views on CPU utilization, component states, POD status, Container status



SEBA FCAPS – OLT

OLT Management

- Managing subscriber services in the POD will require configuring many sub-components of the POD. VOLTHA hardware, switch fabrics, software abstraction, all may require configuration to provide subscriber services.
- A simple abstract model will be provided upstream to simplify subscriber service provisioning
 - PON ports from various VOLTHA hardware components are aggregated through a switching component to a ethernet interface
 - Supports a pluggable or pizza box hardware deployment in an abstract provisioning model
- Assign a descriptive identifier (CLLI e.g.) to the abstract OLT
- Retrieve OLT hardware inventory information
- Manage OLT software and upgrades
- Reset OLT hardware
- Backup and Restore Configuration information (OLT, ONT, Subscriber) for the OLT
- Delete OLT
- Run OLT hardware diagnostics
- Retrieve inventory information for SFP devices plugged into OLT ports
- Provide a summary Health status for the OLT (combine individual component stats)



Example Abstract OLT definition

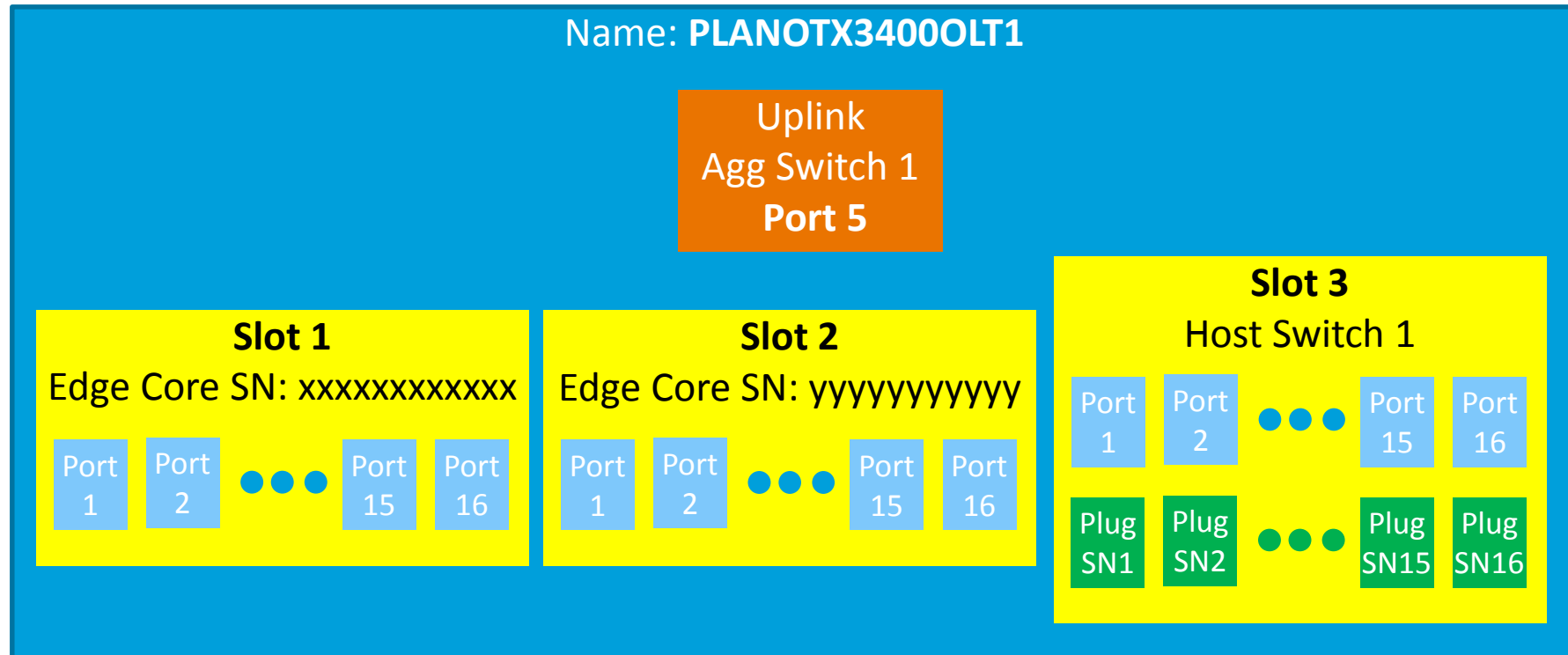

SEBA FCAPS – ONT

ONT Management

- Assign ONT to specific OLT port and assigned ONT number via serial number (or other unique identifier)
- Map upstream ONT identifications (OLT CLI ONT port) to dynamic VOLTHA assignments
- Retrieve ONT hardware inventory information
- Manage ONT software and upgrade
- Reset ONT hardware
- Manage associated ONT database configurations
- Delete ONT hardware
- Run available ONT diagnostics and retrieve result
- Retrieve inventory information for SFP device plugged into the ONT
- Disable the ONT
- Manage the ONT UNI port
 - Reset ONT UNI
 - Disable ONT UNI



SEBA FCAPS – Service Type

Service Type Management

- Create a new service type
 - Name – Identifier of the service type
 - i.e. Residential Service, Business Service
 - Service Type provide a link between service ordering and VOLTHA specific implementation details
 - Allows Northbound systems to be independent of VOLTHA implementation details such as Technology Type and Table ID
 - Defined externally per operator as required by service details
- Retrieve Service Types



SEBA FCAPS – Technology Profile

Technology Profile Management

- Create a new or configure an existing technology profile
 - New Profile ID or Existing Profile ID
 - Technology Type
 - i.e. XGS, G.fast, ...
 - Data Block of key value pair
 - Service Type (optional)
 - This command could change the selected profile for existing service by mapping a new profile ID to an existing service type. The result must be the push of the new profile information to the subscribers.
 - Technology profiles without a service type set will not be usable from the service APIs
- Retrieve Technology Profiles
 - Technology Type



SEBA FCAP – Speed Profile

Speed Profile Management

- Create a new or configure an existing speed profile
 - Name
 - Technology Type
 - Direction (Upstream or Downstream)
 - Data Block of key value pairs
 - PON adapter types would specify the specific metering parameters required to provide the required service
 - Future technology types like G.fast could require additional configuration data similar to what is provided in the technology profiles to provide the proper speeds for the service
 - This command could change the selected profile for existing service by mapping a new configuration to an existing service. The result must be the push of the new profile information to the subscribers.
- Retrieve Speed Profiles
 - Technology Type



SEBA FCAPS – Subscriber Service

Service Management

- Create a new or configure an existing service
 - Abstract OLT Name (CLLI) (as configured with OLT management)
 - This is used to identify specific VOLTHA device IDs and the adapter to be used
 - Pre-provisioning of services will be allowed thus dynamic OLT may not be assigned at time of service order
 - Slot
 - OLT Port
 - ONT Number (as configured with ONT management)
 - This is used to tie the northbound ONT numbering to the dynamic numbering of the VOLTHA
 - Pre-provisioning of services will be allowed thus dynamic ONT may not be assigned at time of service order
 - ONT Port
 - SVLAN
 - CVLAN



SEBA FCAPS – Subscriber Service

Service Management (cont.)

- Create a new or configure an existing service (cont.)
 - Service Type
 - Service type plus technology type will specify technology profile to select
 - Downstream Speed Profile
 - Speed profile plus technology type will specify meters or additional configuration
 - Upstream Speed Profile
 - Speed profile plus technology type will specify meters or additional configuration
- Retrieve Subscriber Services
- Under consideration
 - Authentication String format (optional)
 - Format of identification string to be applied to upstream authentication messages (i.e. RADIUS)
 - DHCP option 82 port identifier format (optional)



SEBA FCAPS - XGS PON Operational Status

Operational Status 802.1x Authenticator

Retrieved Parameters

– Current PAE Authenticator State Machine Status

Initialize	Disconnected	Connecting	Authenticating	Authenticated
Aborting	Held	Force Authentication	Force Unauthentication	

– Current PAE Backend State Machine Status

Request	Response	Success	Fail	Timeout	Idle	Initialize
---------	----------	---------	------	---------	------	------------

– Current Status of the Authenticator

Authorized	Unauthorized
------------	--------------



SEBA FCAPS - XGS PON Operational Status

Operational Status 802.1x Authenticator (cont.)

Retrieved Parameters (cont.)

- Current number of valid EAPOL frames received
- Current number of EAPOL frames transmitted
- Current number of start EAPOL frames received
- Current number of logoff EAPOL frames received
- Current number of response ID EAP frames received
- Current number of response EAP frames received
- Current number of request ID EAP frames transmitted
- Current number of request EAP frames transmitted
- Current number of EAPOL frames received with invalid frame type
- Current number of EAPOL frames received with invalid body length
- Most recently received protocol version
- Most recently received source MAC address



SEBA FCAPS - XGS PON Operational Status

Operational Status 802.1x Diagnostics

Retrieved Parameters

- Connection status
- Number of EAPOL logoff messages received resulting in disconnected state
- Number of authenticating transitions due to EAP response or identity message
- Number of authenticated transitions due to successful authentication
- Number of transitions to aborting due to timeout
- Number of transitions to held due to authentication failure
- Number of transitions to aborting due to reauthentication request
- Number of transitions to aborting due to start request
- Number of transitions to aborting due to logoff request
- Number of transitions to connecting due to reauthentication request
- Number of transitions to connecting due to start request



SEBA FCAPS - XGS PON Operational Status

Operational Status 802.1x Diagnostics (cont.)

Retrieved Parameters (cont.)

- Number of transitions to disconnected due to logoff request
- Number of access request packets sent
- Number of access challenge packets received
- Number of EAP request packets sent due to the authenticator choosing the EAP method
- Number of transitions to response (received response other than NAK)
- Number of EAP success messages received
- Number of EAP failure messages received



SEBA FCAPS - XGS PON Operational Status

Operational Status 802.1x Session

Retrieved Parameters

- Session identifier
- User name of the supplicant PAE
- Session duration
- Session termination reason

Supplicant Logoff	Port Failure	Supplicant Restart	Reauthentication Failed	Force Unauthentication	Force Authentication
Port Reinit	Port Admin	Server	Time Limit	Idle	Nonterminated

- Authentication method

Remote	Local
--------	-------



SEBA FCAPS - XGS PON Operational Status

Operational Status 802.1x Session (cont.)

Retrieved Parameters (cont.)

- Received user data frames
- Received use data octets
- Transmitted user data frames
- Transmitted user data octets



SEBA FCAPS - XGS PON Operational Status

Operational Status RADIUS Accounting Server

Retrieved Parameters

- Operational status of the RADIUS accounting server

Unknown	In use	Unavailable
---------	--------	-------------

- Roundtrip packet time to the accounting server
- Number of access request packets sent to the server
- Number of access request packets retransmitted to the server
- Number of access accept packets sent to the server
- Number of access reject packets sent to the server
- Number of access challenge packets sent to the server
- Number of malformed access response packets received from the server
- Number of access response packets received from the server with an invalid validator



SEBA FCAPS - XGS PON Operational Status

Operational Status RADIUS Accounting Server (cont.)

Retrieved Parameters (cont.)

- Number of access request packets pending a response from the server
- Number of packets to the server which timed out
- Number of packets of an unknown RADIUS type received from the accounting server
- Number of dropped packets received from the accounting server
- Number of packets received from an unknown server



SEBA FCAPS - XGS PON Operational Status

Operational Status Database

Retrieved Parameters

- Database name
- Database version
- Database status



SEBA FCAPS - XGS PON Operational Status

Operational Status Database Download

Retrieved Parameters

- Database download status

Ongoing	Successful	Failed
---------	------------	--------

- Database download failure reason
- IP address of download server
- Path to download



SEBA FCAPS - XGS PON Operational Status

Operational Status IGMP Channel

Retrieved Parameters

- Number of failed join requests due to insufficient access permission
- Number of failed join requests due to insufficient bandwidth
- Number of failed join request due to unknown address
- Number of seconds of overload protection
- Current group number
- Number of failed join requests when maximum number of ports would be exceeded for the multicast port
- Number of failed join requests when maximum number of ports would be exceeded for the system
- Number of failed join requests due to multicast bandwidth limits
- Current number of IGMP channel joins
- Current number of unconfigured group
- Count of the number of general queries that have been transmitted



SEBA FCAPS - XGS PON Operational Status

Operational Status IGMP Channel (cont.)

Retrieved Parameters (cont.)

- Count of the number of group specific queries that have been transmitted
- Count of V1 membership report requests received
- Count of V2 membership report requests received
- Count of V3 membership report requests received
- Count of received leave requests
- Count of valid IGMP packets received
- Count of invalid IGMP packets received
- Count of unknown IGMP type packets received
- Count of IGMP packets dropped because of invalid length
- Count of IGMP packets dropped because of invalid IP header checksum
- Count of IGMP packets dropped because of invalid IGMP header checksum
- Count of group specific queries sent on channel
- Count of reports received with wrong mode



SEBA FCAPS - XGS PON Operational Status

Operational Status IGMP Data

Retrieved Parameters

- Total number of messages received
- Total number of IGMP messages received
- Total number of invalid IGMP messages received
- Total number of join requests
- Total number of successful join and rejoin requests
- Total number of failed join requests
- Total number of connects
- Total number of leaves requests
- Total number of disconnects
- Peak number of connections established per second
- Duration of the peak connections per second



SEBA FCAPS - XGS PON Operational Status

Operational Status IGMP Data (cont.)

Retrieved Parameters (cont.)

- Peak number of disconnects performed per second
- Duration of peak number of disconnects
- Peak number of messages received per second
- Duration of peak messages received
- Total number of currently connected roots
- Total number of seconds with overload protection applied
- Number of seconds of IGMP operation
- Total number of GMQ member query requests
- Total number of GSQ specific query requests
- Total number of identified connected groups
- Total number of unidentified connected groups
- Total number of connected groups in the reserved state (due to hysteresis)
- Total number of GSSQ source specific query requests



SEBA FCAPS - XGS PON Operational Status

Operational Status Multicast Source

Retrieved Parameters

- Source address for multicast channel
- Multicast channel VLAN id



SEBA FCAPS - XGS PON Operational Status

Operational Status ONT

Retrieved Parameters

- Estimated distance between ONT and OLT
- PLOAM Status – active alarm status

Loss of Signal	Loss of Acknowledgement	Loss of GEM Channel Delineation	Physical Equipment Error	Start-Up Failure	Signal Degrade
ONT Disabled	Message Error Message	Inactive	Loss of Frame	Signal Fail	Dying Gasp
Deactivation Failure	Loss of PLOAM	Drift of Window	Remote Defect Indication	Loss of Key Synchronization	Differential Reach Exceeded



SEBA FCAPS - XGS PON Operational Status

Operational Status ONT Alarm Interface

Yang Definition

- WT-383

Retrieved Parameters

- Total optics signal level
 - Ability to configure a low threshold alarm
 - Ability to configure a high threshold alarm



SEBA FCAPS - XGS PON Operational Status

Operational Status ONT Locally Persisted Data

Retrieved Parameters

- Date and time ONT data persisted to flash
- Also need the ability to persist the active configuration to flash



SEBA FCAPS - XGS PON Operational Status

Operational Status ONT UNI Port

Retrieved Parameters

– Ethernet Status

Not Detected	10 Base T Half Duplex	100 Base T Half Duplex	1000 Base T Half Duplex
	10 Base T Full Duplex	100 Base T Full Duplex	1000 Base T Full Duplex

– Link Status

Up	Down
----	------



SEBA FCAPS - XGS PON Operational Status

Operational Status Current Optical Data

Retrieved Parameters

- ONT Receive optical signal level
- ONT Transmit optical signal level
- ONT Optical module temperature
- ONT Optical module voltage
- ONT Laser bias current
- OLT Receive optical signal level
- OLT Transmit optical signal level
- OLT Optical module temperature
- OLT Optical module voltage
- OLT Laser bias current



SEBA FCAPS - XGS PON Operational Status

Operational Status Historical Optical Data

Retrieved Parameters

- Date and time of measurement (stored for multiple intervals)
- ONT Receive optical signal level
- ONT Transmit optical signal level
- ONT Optical module temperature
- ONT Optical module voltage
- ONT Laser bias current
- OLT Receive optical signal level
- OLT Transmit optical signal level
- OLT Optical module temperature
- OLT Optical module voltage
- OLT Laser bias current



SEBA FCAPS - XGS PON Operational Status

Operational Status PON

Retrieved Parameters

- Bit Error Count Downstream
 - Also need the ability to reset this count
- Bit Error Count Upstream
 - Also need the ability to reset this counter
- Ranged Indication

ONT is ranged	ONT is not ranged	ONT is manually disabled	ONT is automatically disabled
---------------	-------------------	--------------------------	-------------------------------



SEBA FCAPS - XGS PON Operational Status

Operational Status PON SFP

Retrieved Parameters

- Vendor SFP Name
- Vendor SFP Part Number
- Serial Number
- Manufacture Date



MOBILIZING
YOUR
WORLD™

